

CrazyDrill™ Twicenter

Mikron Tool 



The center drill
with a double advantage

CRAZYDRILL™
by Mikron Tool
Twicenter

Center and Chamfer – in one single step

CRAZYDRILL™
by Mikron Tool
Twicenter

Traditional design:

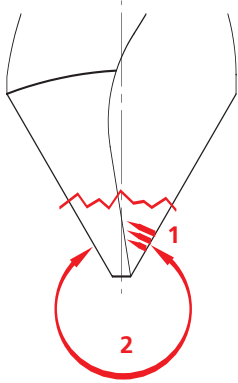

1. Missing space for chips and not ideal direction of chip flow leads towards chip accumulation and higher pressure: risk of breakage
2. 60° / 90° tip angle results in insufficient cutting speed and high pressure on the tip: risk of breakage
3. Large web requires high penetration force and causes high pressure on the tip: risk of breakage

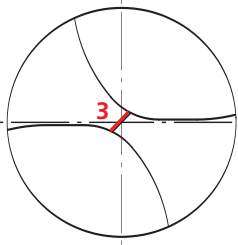

CrazyDrill Twicenter:

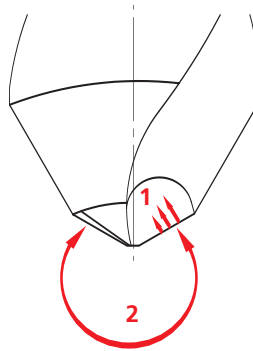

1. 130° tip angle favors free chip flow directly towards the flutes
2. 130° tip angle reduces the pressure on the tip
3. Short web reduces penetration force on the tip
4. Through tool coolant supply guarantees optimal cooling and lubrication

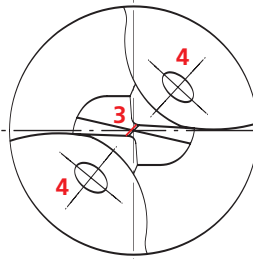

The double tip

Three versions for different chamfers.

For chamfers of 60° and 90° the double tip guarantees excellent rigidity.

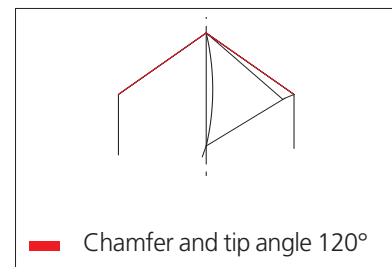
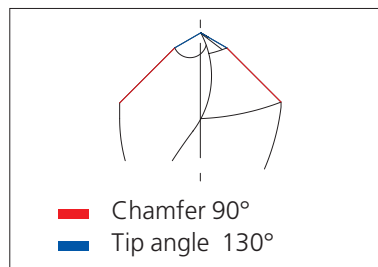
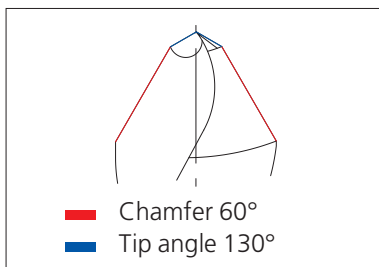

5 advantages

- Centering and chamfering in one single step
- High process reliability due to robust tip angle
- Each CrazyDrill Twicenter can prepare the holes for various drill diameters
- Increased tool life due to through tool coolant and matching coating
- Recommended for machining with and without through tool coolant capabilities

Coolant supply



inside



outside

Centering – chamfering 60°

CrazyDrill Twicenter for a chamfer of 60°

Item number	d ₁ mm	d ₂ mm	l mm	D	drill angle	Chamfer	L mm
CC.03010.60	0.3	1.0	6.0	3	130	60°	40
CC.05014.60	0.5	1.4	6.0	3	130	60°	40
CC.10020.60	1.0	2.0	6.0	3	130	60°	40
CC.15030.60	1.5	–	6.0	3	130	60°	40
CC.20040.60	2.0	–	8.0	4	130	60°	50
CC.30060.60	3.0	–	12.0	6	130	60°	60
CC.40080.60	4.0	–	16.0	8	130	60°	70
CC.60100.60	6.0	–	20.0	10	130	60°	80

All tools are coated

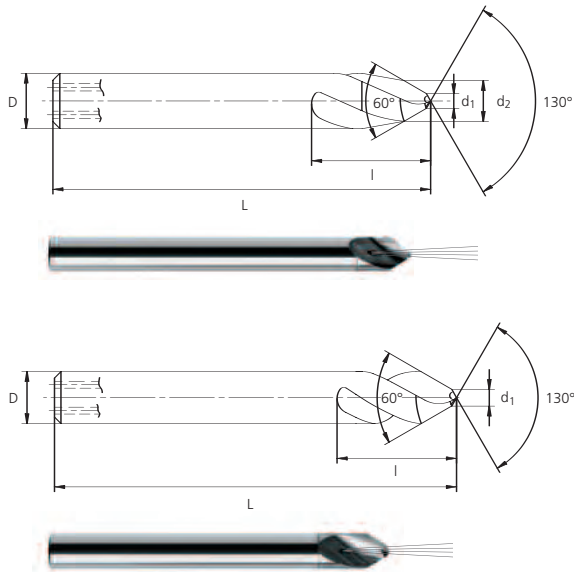

The optimal chamfer

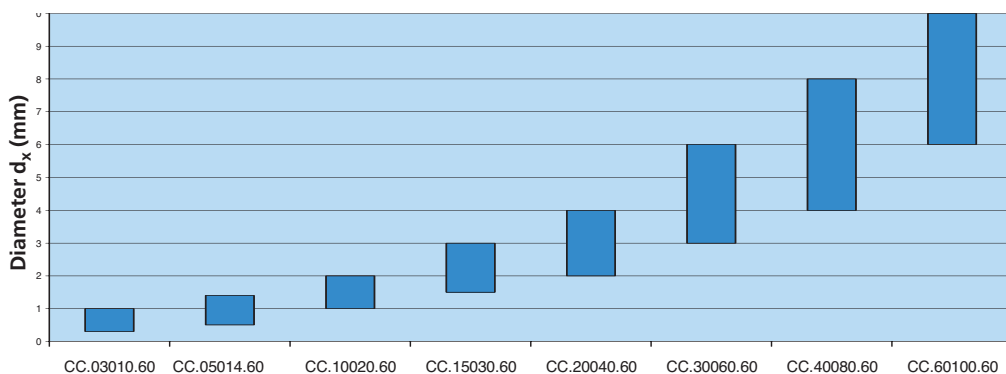

Each center drill is capable to prepare for drilling of various diameters and to perform chamfers with different sizes.

ø d _x	l _x - drilling depths, in relation to required chamfer diameter (with chamfer of 60°)							
	CC.03010.60	CC.05014.60	CC.10020.60	CC.15030.60	CC.20040.60	CC.30060.60	CC.40080.60	CC.60100.60
0.4	0.16							
0.8	0.50	0.38						
1		0.55						
1.5			0.67					
2				0.78				
2.5				1.22	0.90			
3					1.33			
3.5					1.77	1.13		
4						1.57		
5						2.43		
6							1.80	
7							2.66	
8							3.53	2.26
9								3.13
10								4.00

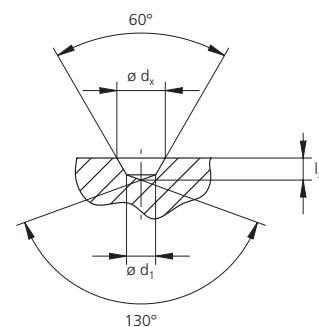

For each required diameter, including the chamfer, a certain drill depth has to be maintained. (Please ask for a complete dimension table, if required)

Centering – chamfering 90°

CrazyDrill Twicenter for a chamfer of 90°

Item number	d ₁ mm	d ₂ mm	l mm	D	drill angle	Chamfer	L mm
CC.03010.90	0.3	1.0	6.0	3	130	90°	40
CC.05014.90	0.5	1.4	6.0	3	130	90°	40
CC.10020.90	1.0	2.0	6.0	3	130	90°	40
CC.15030.90	1.5	–	6.0	3	130	90°	40
CC.20040.90	2.0	–	8.0	4	130	90°	50
CC.30060.90	3.0	–	12.0	6	130	90°	60
CC.40080.90	4.0	–	16.0	8	130	90°	70
CC.60100.90	6.0	–	20.0	10	130	90°	80

All tools are coated

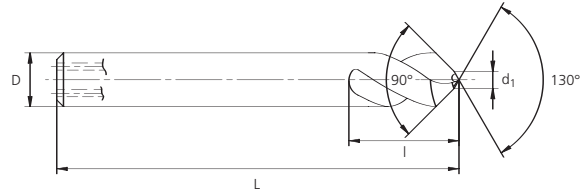
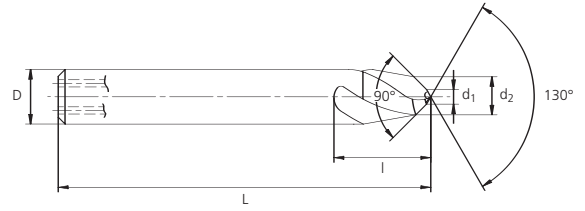

The optimal chamfer

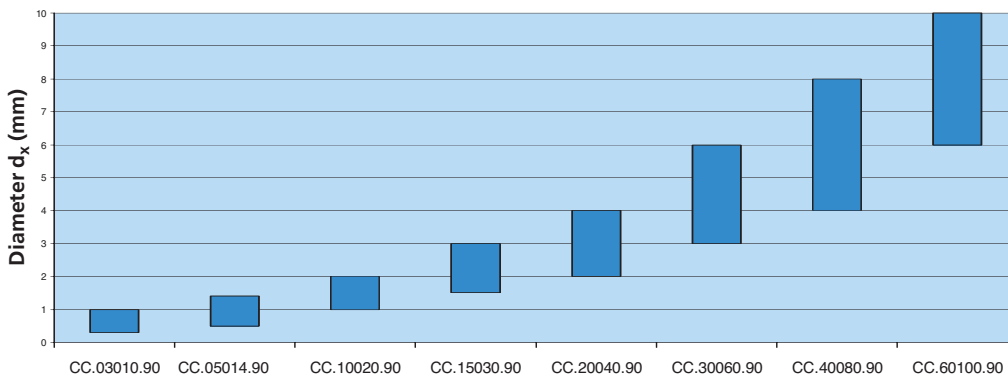

Each center drill is capable to prepare for drilling of various diameters and to perform chamfers with different sizes.

l _x - drilling depths, in relation to required chamfer diameter (with chamfer of 90°)								
Ø d _x	CC.03010.90	CC.05014.90	CC.10020.90	CC.15030.90	CC.20040.90	CC.30060.90	CC.40080.90	CC.60100.90
0.4	0.12							
0.8	0.32							
1		0.27						
1.5		0.37						
2			0.48					
2.5				0.60				
3				0.85	0.72			
3.5					0.97			
4					1.22	0.95		
5						1.20		
6						1.70	1.43	
7							1.93	
8							2.43	1.90
9							2.40	2.90

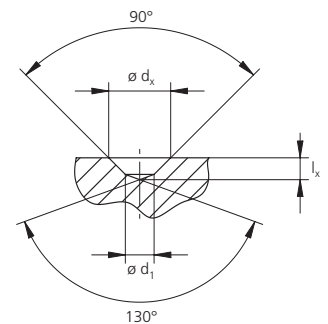

For each required diameter, including the chamfer, a certain drill depth has to be maintained. (Please ask for a complete dimension table, if required)

Centering – chamfering 120°

CrazyDrill Twicenter for a chamfer of 120°

Item number	d mm	l mm	D	drill angle	Chamfer	L mm
CC.00050.120	0.5	7.5	3	120	120°	40
CC.00100.120	1.0	6.1	3	120	120°	40
CC.00200.120	2.0	6.0	3	120	120°	40
CC.00300.120	3.0	8.0	3	120	120°	40
CC.00400.120	4.0	10.0	4	120	120°	50
CC.00600.120	6.0	15.0	6	120	120°	60
CC.00800.120	8.0	17.0	8	120	120°	70
CC.01000.120	10.0	19.0	10	120	120°	80

All tools are coated

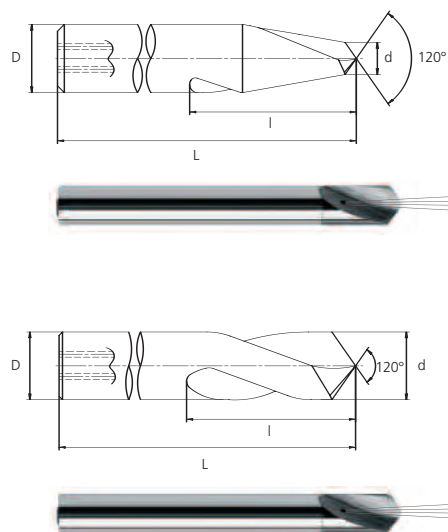

Guidelines for cutting parameters

CRAZYDRILL™
by Mikron Tool
Twicenter

Materials to be machined	Examples	Cutting speed vc m/min	Feed f in mm/revolution in relation to diameter (indicative)							
			Chamfer ø 0.3 - 1.0 mm	Chamfer ø 0.5 - 1.4 mm	Chamfer ø 1.0 - 2.0 mm	Chamfer ø 1.5 - 3.0 mm	Chamfer ø 2.0 - 4.0 mm	Chamfer ø 3.0 - 6.0 mm	Chamfer ø 4.0 - 8.0 mm	Chamfer ø 6.0 - 10.0 mm
Low-alloy steels	Ck45, 16MnCr5, 20MnCr6	120	0.03	0.05	0.08	0.10	0.12	0.15	0.20	0.25
Low-alloy tool steels	100Cr6, 90MnCrV8	80	0.03	0.05	0.08	0.10	0.12	0.15	0.20	0.25
High-alloy steels	G-X 100 CrMoV 5 1, X210CeW12, S 18-1-2-10	60	0.02	0.03	0.04	0.06	0.08	0.12	0.18	0.23
Steels with hardness >50HRC	90MnCrV8, X40CrV5-1	40	0.01	0.02	0.03	0.04	0.05	0.06	0.07	0.08
Ferritic Inox steels	X17CrNi16-2, X6CrMo 17-1, X20Cr13, G-X130CrSi29	50	0.02	0.03	0.04	0.06	0.08	0.10	0.12	0.15
Austenitic Inox steels	X5CrNi 18-10	50	0.02	0.03	0.04	0.06	0.07	0.09	0.11	0.13
Cast iron	GG20 - GG50; GGG40 - GGG70	100	0.03	0.04	0.05	0.07	0.09	0.11	0.15	0.20
Titanium and Titanium alloys	Ti.Gr2, Ti.Gr.5	25	0.03	0.04	0.07	0.09	0.11	0.14	0.18	0.22
Aluminum alloy, wrought	6061-T6, AlCuMg1, Certal	150	0.04	0.06	0.09	0.11	0.13	0.18	0.23	0.30
Aluminum alloy, cast	G-ALSi9Cu3, G-ALSi7Mg	100	0.04	0.06	0.09	0.11	0.13	0.18	0.23	0.30
Copper alloy, easy machinable	CuZn39Pb2	100	0.04	0.06	0.09	0.11	0.13	0.16	0.18	0.20
Copper alloy, difficult to machine	Cu, CuZn10, CuZn30, CuNi18Zn20	80	0.04	0.06	0.09	0.11	0.13	0.16	0.18	0.20

These are approximate values. Different conditions due to machine type, spindle, coolant, etc. can influence the performance.

Important criteria:

For best results, Mikron Tool recommends the use of cutting oil as lubricant and coolant. The use of water based coolant or minimum quantity lubrication is also possible. For the later, reduced cutting parameters are required.

Services that complete the concept

Engineering and Consulting

Mikron Tool advises its customers on the selection of suitable tools with respect to material and geometry, necessary tolerances and ideal operating parameters, and partners with them from the initial trials through mass production.

Star-Service

With the Star Service (Standard Tool Adjustment & Record Service), Mikron Tool also offers high-performance drills in dimensions outside the standard range.

Regrinding

CrazyDrill with a diameter of 1.5 mm or more can be reground and recoated which considerably increases the cost-effectiveness of this drill. Mikron Tool offers this service in Agno (Switzerland) as well as in Rottweil (Germany).

Packaging

Practical packaging provides optimum protection for the tool and allows easier, safer handling without the risk of personal injury or tool damage.

Recycling

Worn tools (CrazyDrill and special tools) are taken back by Mikron Tool, and the material is recycled – holding true our statement in our environmental certificate.

Certifications

Mikron Tool is certified to:
ISO 9001:2000 for quality
ISO 14001:2004 for environment
OHSAS 18001:1999 for occupational health and safety management.

CrazyDrill products are supplied with a Quality Certificate and an instruction for safe handling.



High performance tools from Mikron Tool

CrazyDrill: for large production lots and materials difficult to machine.

CrazyDrill is ideally suited for high volume production of precision parts. CrazyDrill offers, comparing to standard drills, much higher cutting speeds and feeds.



MiquDrill: for smaller production lots and a variety of work pieces

Mikron Tool standard quality drills MiquDrill are the perfect solution for the machining of small to midsize work pieces, guaranteeing at the same time quality and process reliability.



Special tools: customer tailored solutions for machining of precision parts

Developed for particular machining operations; special tools guarantee the best conditions for a process-sure, efficient machining of precision parts.

Special tools



Your contacts

Headquarter and Production:

Mikron Tool SA Agno
P.O. Box 340
6934 Bioggio
Switzerland
Phone +41 91 610 40 00
Fax +41 91 610 40 10
mto@mikron.com

Production for Germany
and Regrinding EU:

Mikron GmbH Rottweil
Abteilung Werkzeuge
Bernler Feld 71
78628 Rottweil
Germany
Phone +49 741 5380 450
Fax +49 741 5380 480
info.mtr@mikron.com

Japan:

Mikron Ltd. Tokyo
Shin-Yokohama, Kohoku-Ku
Yokohama City 222-0033
Japan
Phone +81 45 472 10 01
Fax +81 45 472 20 22
mfe@mikron.com

North and South America Sales:

Mikron Corp. Monroe
P.O. Box 268
600 Pepper Street
Monroe, CT 06468
USA
Phone +1 203 261 3100
Fax +1 203 268 4752
mmo@mikron.com

