

ZX

HIGH PERFORMANCE GEOMETRIES FOR TOP-LINE

New

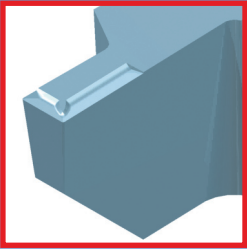
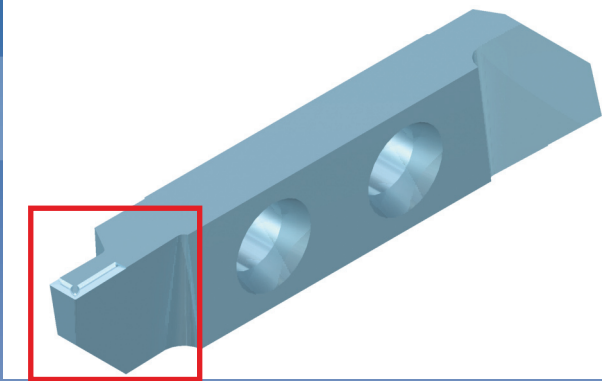

très bonne maîtrise du copeau
pour matières difficiles



sehr gute Spankontrolle
für schwierige Werkstoffe

very efficient chip control
for difficult materials

multitude de géométries possibles



mehrere mögliche Spangeometrien

much possible geometries

APPLITEC

SWISS TOOLING



foncer tourner
einstechen und drehen
grooving and turning



pour une avance à partir de 0.02 mm
für Vorschub ab 0.02 mm
for Feed from 0.02 mm

764 ZX

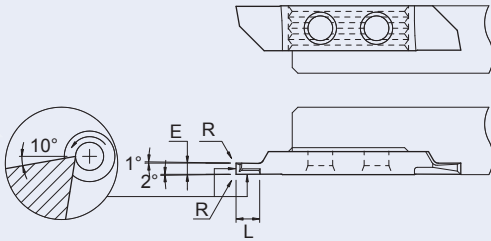

E	R	L	Art. N°	TIN	TIALN	N (µK20)
1.5	0.03	4	764zx10-1.5-R03	<input type="checkbox"/>	<input checked="" type="checkbox"/>	<input type="checkbox"/>
2.0	0.08	4	764zx10-2.0-R08	<input type="checkbox"/>	<input checked="" type="checkbox"/>	<input type="checkbox"/>
2.5	0.08	5	764zx10-2.5-R08	<input type="checkbox"/>	<input checked="" type="checkbox"/>	<input type="checkbox"/>
3.0	0.08	6	764zx10-3.0-R08	<input type="checkbox"/>	<input checked="" type="checkbox"/>	<input type="checkbox"/>
4.0	0.2	6	764zx10-4.0-R20	<input type="checkbox"/>	<input checked="" type="checkbox"/>	<input type="checkbox"/>

744 ZX

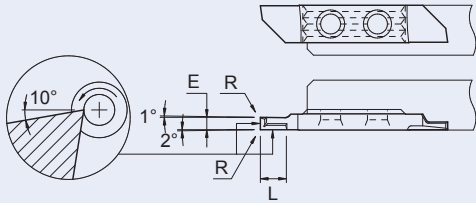

1.5	0.01	4	744zx10-1.5	<input type="checkbox"/>	<input checked="" type="checkbox"/>	<input type="checkbox"/>
2.0	0.01	4	744zx10-2.0	<input type="checkbox"/>	<input checked="" type="checkbox"/>	<input type="checkbox"/>

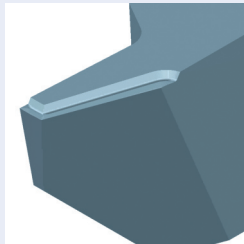
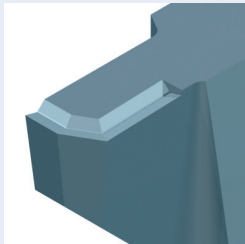

autres géométries possibles
sur demande

other geometries
also possible on request

andere Spangeometrien
auch möglich auf Anfrage

7XX-XX-B



serrage type B sur demande
B-Spannsystem auf Anfrage
B clamping system on request

■ = Standard

□ = Sur demande / Auf Anfrage / On request